



MULTITURN ABSOLUTE ENCODERS EAM PARALLEL - SSI



Description of the PARALLEL multiturn absolute encoder

The EAM range of parallel multiturn absolute encoders was studied for applications requiring high accuracy, also on extended linear development; they are available with resolution levels up to 13 bits and therefore 8192 Positions/Turn on the turn and with resolution levels of up to 12 bits, 4096 Positions/turn for turns. The robust mechanics and the different types of flanging mean that it can be used in a broad range of applications, guaranteeing correct operation, even in the most arduous conditions.

This range of encoders is available with cable or connector output and as for the single turn, they can reach a level of protection up to IP66, depending on the model. The output configurations are both grey code and binary and the output electronics cover all fields of application being available in the NPN, NPN OPEN COLLECTOR, PNP and PUSH PULL formats.

Description of the SSI multiturn absolute encoder

The range of multi-turn absolute encoders with SSI format output, supply the data in this format, created by technology already introduced into the single turn. The use of this standard increases the efficacy of this type of encoder; this is because the amount of data of a multi-turn is much higher and the serial approach becomes an optimum solution to the growing number of wires.

For this series in fact, the output data is formed by a 25 bit word, as the standard in which the useful bits are numerically proportional to the resolution chosen for the encoder.

This type of transmission therefore considerably reduces the wiring problem, while maintaining the device performance the same. In this encoder range, the data connections are reduced, as for the single turn, to just four wires; one pair for the position code and one for the clock signal, both in differential logic. The mechanical components, above all the flanging available are highly diverse and capable of satisfying the most widely ranging demands.

Ordering codes for multiturn absolute encoder

PARALLEL

In case of a particular Customer variant separate by a full stop

EAM 63 A 4096 / 4096 G 5 P P X 10 X 3 MA R . XXX

EAM = multiturn absolute encoder

58 = body dimension
63 = body dimension
90 = body dimension
115 = body dimension

A = mod.EAM 63 / 90 / 115
B = mod.EAM58
C = mod.EAM58
D = mod.EAM63 Type of flanges
E = mod.EAM63
F = mod.EAM63
G = mod.EAM63

2 / 4 / 8 / 16 / 32 / 64 / 128 / 256 / 512 / 1024 / 2048 / 4096 Turns

2 / 4 / 8 / 16 / 32 / 64 / 128 / 256 / 512 / 1024 / 2048 / 4096 / 8192 Resolutions
 N.B.: For impulse availability contact our offices

B = Binary
G = Gray (Standard) Code

5
8 ÷ 28 Encoder power supply (Vdc)

N = NPN (Standard negative logic)
C = NPN OPEN COLLECTOR (Standard negative logic)
R = PNP (Standard positive logic)
U = PNP OPEN COLLECTOR (Standard positive logic)
P = PUSH PULL with short circuit protection (Standard positive logic)
Electronics output configuration
 N.B.: For the optionals on the output configurations contact our offices

XXX = Special Customer variants indicated by a progressive number from 001 to 999

R = radial
A = axial

PD = 16 poles cable standard output cable 1.5 m
PE = 32 poles cable standard output cable 1.5 m
MA = Connector "MS" type 19 poles
ME = Connector "MS" type 32 poles

3 = 3000 with IP66 R.P.M.
6 = 6000

X = IP54 for EAM63G / F
 IP64 excluding EAM63G / F Protection
S = optional IP66 excluding EAM63G / F - EAM115A

6 = ø 6g6 mm -- 58B
8 = ø 8g6 mm -- 58B -- 63A / D / E -- 90A
9 = ø 9.52g6 mm -- 63 A / D / E -- 90A Shaft diameter
10 = ø 10g6 mm -- 58B / C -- 63A / D / E -- 90A -- 115A
11 = ø 11g6 mm -- 115A

8 = ø 8H7 mm
9 = ø 9H7 mm
10 = ø 10H7 mm
12 = ø 12H7 mm
14 = ø 14H7 mm
15 = ø 15H7 mm
Hole diameter only for mod.63 G / F

L = Latch to indicate only with binary code
T = Tristate only with Push Pull electronic
V = both L + T to indicate only with binary code
X = to indicate if not use Options

N = Negative
P = Positive Logics

Output connections for multiturn absolute PARALLEL encoder

FUNCTION	B / G	16 WAY CABLE COLOUR	32 WAY CABLE COLOUR	PIN M19MP	PIN M32MP
bit 1 (LSB)	B ⁰ / G ⁰	green	green	A	A
bit 2	B ¹ / G ¹	yellow	yellow	B	B
bit 3	B ² / G ²	blue	blue	C	C
bit 4	B ³ / G ³	brown	brown	D	D
bit 5	B ⁴ / G ⁴	pink	pink	E	E
bit 6	B ⁵ / G ⁵	white	white	F	F
bit 7	B ⁶ / G ⁶	gray	Gray	G	G
bit 8	B ⁷ / G ⁷	violet	violet	H	H
bit 9	B ⁸ / G ⁸	gray/pink	gray/pink	J	J
bit 10	B ⁹ / G ⁹	white/green	white/green	K	K
bit 11	B ¹⁰ / G ¹⁰	brown/green	brown/green	L	L
bit 12	B ¹¹ / G ¹¹	white/yellow	white/yellow	M	M
bit 13	B ¹² / G ¹²	Yellow/brown	yellow/brown	N	N
bit 14	B ¹³ / G ¹³	/	White/gray	P	P
bit 15	B ¹⁴ / G ¹⁴	/	gray/brown	R	R
bit 16	B ¹⁵ / G ¹⁵	/	white/pink	S	S
bit 17	B ¹⁶ / G ¹⁶	/	pink/brown	/	T
bit 18	B ¹⁷ / G ¹⁷	/	white/blue	/	U
bit 19	B ¹⁸ / G ¹⁸	/	brown/blue	/	V
bit 20	B ¹⁹ / G ¹⁹	/	white/red	/	W
bit 21	B ²⁰ / G ²⁰	/	brown/red	/	X
bit 22	B ²¹ / G ²¹	/	white/black	/	Y
bit 23	B ²² / G ²²	/	brown/black	/	Z
bit 24	B ²³ / G ²³	/	gray/green	/	a
bit 25	B ²⁴ / G ²⁴	/	yellow/pink	/	d
LATCH	/	/	yellow/gray	/	e
TRISTATE	/	/	pink/green	/	f
0 Volt	/	black	black	T	j
U / D	/	red/blue	red/blue	U	g
+ Vdc	/	red	red	V	h

Connector or cable choice

According to the resolution on turn and to the turns number chose is possible to calculate the necessary connections of the connector or of the cable to use.

From the table below is possible to get the connections number:

Resolutions on turn + Turns number:

Resolution / N° Turns	Bit Number	Connections Number
2	1	1
4	2	2
8	3	3
16	4	4
32	5	5
64	6	6
90 128	7	7
180 / 225 / 250 256	8	8
360 / 450 / 500 512	9	9
720 / 900 / 1000 1024	10	10
1440 / 1800 / 2000 2048	11	11
2880 / 3600 / 4000 4096	12	12
8192	13	13

EXAMPLE 1 :

Resolutions/Turn 256 = 8 connections
N° Turns 32 = 5 connections
Total connections 13.

EXAMPLE 2 :

Resolutions/Turn 4096 = 12 connections
N° Turns 4096 = 12 connections
Total connections 24.

From 1 to 13 connections to consider 16 poles cable or 19 poles connector.

From 14 to 25 connections to consider 32 poles cable or 32 poles connector.

N.B. : if optional signals are used directly chose 32 poles cable or connector.

Ordering codes for multiturn absolute encoder

SSI

In case of a particular Customer variant separate by a full stop

EAM 63 A 4096 / 4096 G 5 S X X 10 X 3 MC R . XXX

EAM = multiturn absolute encoder

58 = body dimension
63 = body dimension
90 = body dimension
115 = body dimension

A = mod.EAM 63 / 90 / 115
B = mod.EAM58
C = mod.EAM58
D = mod.EAM63 **Type of flanges**
E = mod.EAM63
F = mod.EAM63
G = mod.EAM63

2 / 4 / 8 / 16 / 32 / 64 / 128 / 256 / 512 / 1024 / 2048 / 4096 **Turns**

2 / 4 / 8 / 16 / 32 / 64 / 128 / 256 / 512 / 1024 / 2048 / 4096 / 8192 **Resolutions**
 N.B.: For impulse availability contact our offices

B = Binary **Code**
G = Gray (Standard)

5
8 ÷ 28 **Encoder power supply (Vdc)**

S = SSI (Serial Synchronous Interface) **Electronics output configuration**
 N.B.: For the optionals on the output configurations contact our offices

XXX = Particular Customer variants indicated by a progressive number from 001 to 999

R = radial
A = axial

PC = 12 poles cable standard output cable 1.5 m
MC = Connector "MS" type 7 poles
HA = Connector 12 poles

3 = 3000 with IP66 **R.P.M.**
6 = 6000

X = IP54 for EAM63G / F IP64 excluding EAM63G / F **Protection**
S = optional IP66 excluding EAM63G / F -EAM115A

6 = ø 6g6 mm -- 58B
8 = ø 8g6 mm -- 58B -- 63A / D / E -- 90A
9 = ø 9.52g6 mm -- 63A / D / E -- 90A **Shaft diameter**
10 = ø 10g6 mm -- 58B / C -- 63A / D / E -- 90A -- 115A
11 = ø 11g6 mm -- 115A

8 = ø 8H7 mm
9 = ø 9.52H7 mm
10 = ø 10H7 mm
12 = ø 12H7 mm
14 = ø 14H7 mm
15 = ø 15H7 mm **Hole diameter only for mod.63 F / G**

X = not to utilize **Options**

X = not to utilize **Logics**

Output connections for multiturn absolute SSI encoder

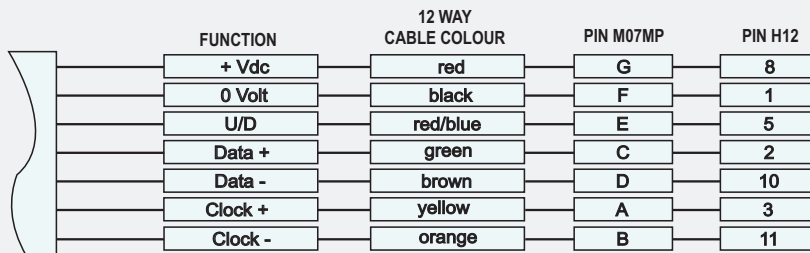

EAM63A

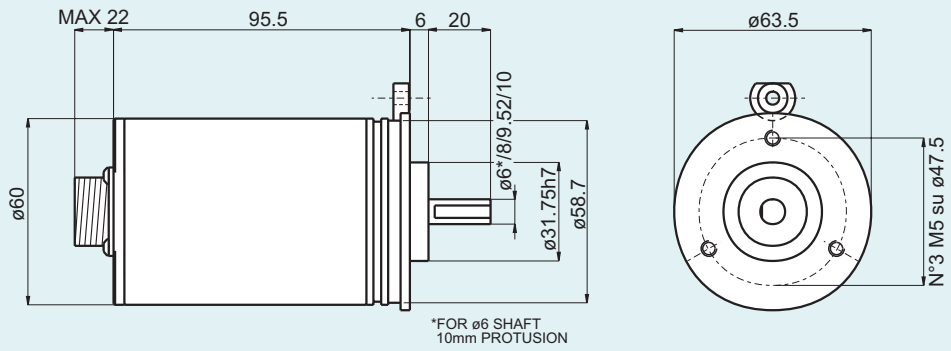

EAM58B

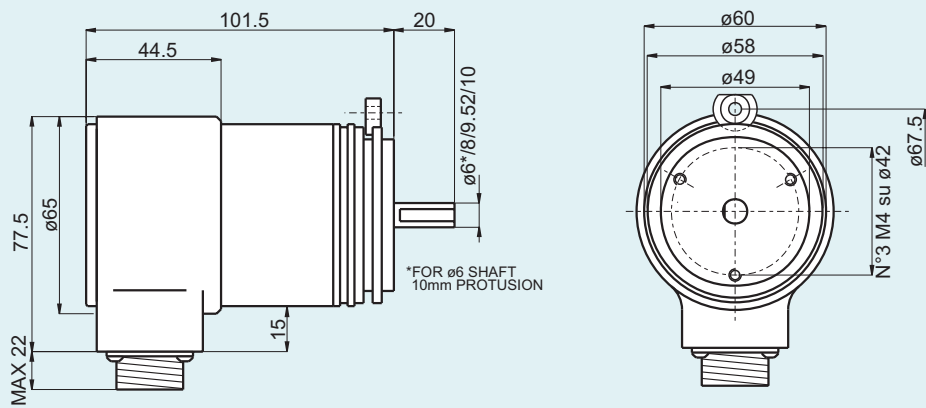

EAM58C

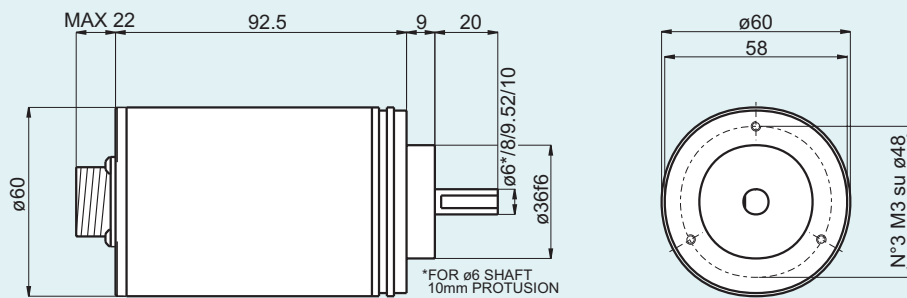

EAM63D - EAM63E

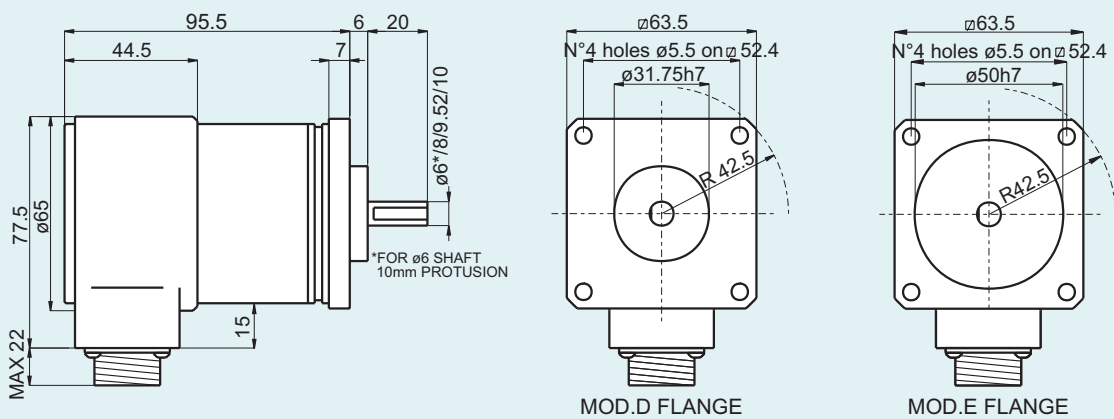

EAM63F - EAM63G

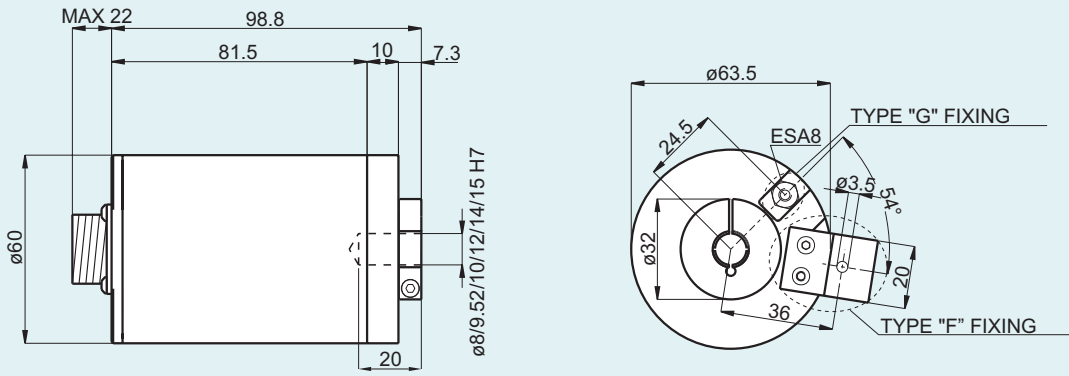

EAM90A

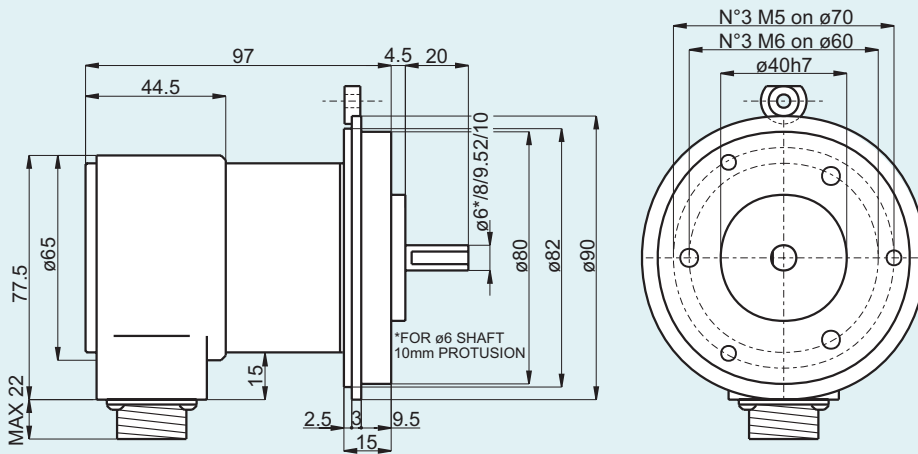

EAM115A

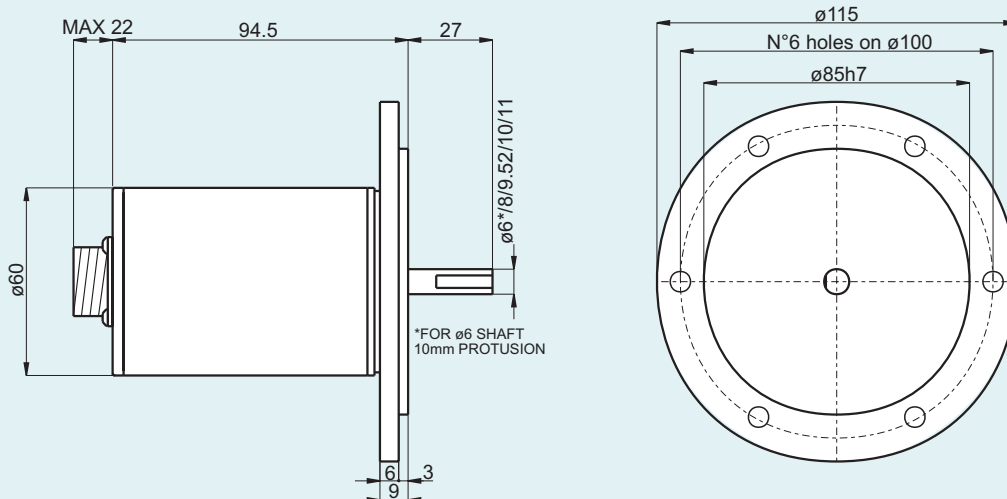

Environmental Characteristics

Protection	IP54 standard --63G/F IP64 standard --58B/C --63A/D/E --90A --115A IP66 optional --58B/C --63A/D/E --90A
Operating Temperature	0° + +60°C
Storage Temperature	-15° + +70°C

Electronic Characteristics PARALLEL

Turns	2 / 4 / 8 / 16 / 32 / 64 / 128 / 256 / 512 / 1024 / 2048 / 4096
Resolutions / Turn	2 / 4 / 8 / 16 / 32 / 64 / 128 / 256 / 512 / 1024 / 2048 / 4096 / 8192
Power supply	5 Vdc / 8 + 28 Vdc
Current consumption without load	150 mA
Max commutable current	40 mA per channel
Electronic output configuration	NPN (negative logic) NPN Open Collector (negative logic) PNP (positive logic) PNP Open Collector (positive logic) PUSH PULL (positive logic)
Max output frequency	100 KHz output code $F = \frac{\text{RPM} \times \text{Resolution}}{60}$
Accuratezza	+/- 1/2 LSB

Electronic Characteristics SSI

Turns	2 / 4 / 8 / 16 / 32 / 64 / 128 / 256 / 512 / 1024 / 2048 / 4096
Resolutions / Turn	2 / 4 / 8 / 16 / 32 / 64 / 128 / 256 / 512 / 1024 / 2048 / 4096 / 8192
Power supply	5 Vdc / 8 + 28 Vdc
Current consumption without load	150 mA
Electronic output configuration	SSI (Serial Synchronous Interface)
Monostable time	10 - 25 ms
Time between two clock sequences	> 35 ms
Frequency range	100 KHz - 1 MHz
Accuracy	+/- 1/2 LSB

Mechanical Characteristics

Shaft diameters (mm)	ø6 g6 -- 58B ø8 g6 -- 58B -- 63A/D/E -- 90A ø9.52(3/8") g6 -- 63A/D/E -- 90A ø10 g6 -- 58B/C -- 63A/D/E -- 90A -- 115A ø11 g6 -- 115A
Hole diameters (mm)	ø8 H7 --63F/G ø9 H7 --63F/G ø10 H7 --63F/G ø12 H7 --63F/G ø14 H7 --63F/G ø15 H7 --63F/G
R.P.M. Max	6000 continuous 3000 continuous for --63F/G 3000 with Ip66
Max shaft load	10 N (1 Kp) axial with shaft ø6 20 N (2 Kp) radial with shaft ø6 100 N (10 Kp) axial 100 N (10 Kp) radial
Shock	50 G per 11 msec
Vibrations	10G 10 + 2000 Hz
Bearings life	10 ⁹ revolutions
Bearings	n°2 ball bearings
Shaft material	Stainless steel AISI303
Body material	Aluminium -UNI 9002/5- (D11S)
Cover material	Aluminium alloy 6060
Flange material	Aluminium -UNI 9002/5- (D11S)
Weight	~ 600 g --58B/C--63A/D/E/F/G ~ 800 g --90A--115A

