

Linear actuator DSZY13-STD-ER2

DSZY13 electric linear actuators are required in a wide variety of applications. Therefore, it is available in three models:

1. **DSZY13-STD-ER2**
(with external, adjustable limit switches)
2. **DSZY13-HS-ER2**
(additionally with Hall sensor for incremental position feedback)
3. **DSZY13-POT-ER2**
(additionally with potentiometer for absolute position feedback)

Equipped with a ball screw spindle, it is a durable and robust DC linear drive, thus achieving high self-locking. In addition, mechanical overload protection has been integrated. All models contain external quick and easy adjustable limit switches (reed sensors).



Type code (all options can be combined)

DSZY13 -	12	-	10	-	200	-	STD	-	ER2-NC	-	IP66
Type	Input Voltage		Gear reduction i		Stroke		Model		External limit switches		IP Code
	12 Vdc		05		100 mm		STD: standard		- ER2-NC		optionally:
	24 Vdc		10		150 mm		(without internal limit		(normally close)		IP69K
			20		200 mm		switches, without position		- ER2 - NO		
			30		300 mm		feedback)		(normally open)		
			40		450 mm						
					600 mm						

Performance data: Load – Speed – Current

Gear reduction i	Dynamic Load (N)	Static load (N)	Typical speed * (mm/s)		Typical current * (A)			
			minimum load	maximum load	minimum load		Maximum load	
					12 Vdc	24 Vdc	12 Vdc	24 Vdc
5	2,500	approx. 5,000	67.1	47.2	3.4	2.6	26.4	13.2
10	3,500	approx. 6,000	33.5	26.7	2.6	1.6	17.6	8.6
20	4,500	approx. 8,000	16.8	14.3	2.6	1.6	13.2	6.6
30	6,000	approx. 11,000	11.2	9.8	2.6	1.6	12.1	6.1
40	7,000	13,600	8.4	7.4	2.6	1.6	11.0	5.5

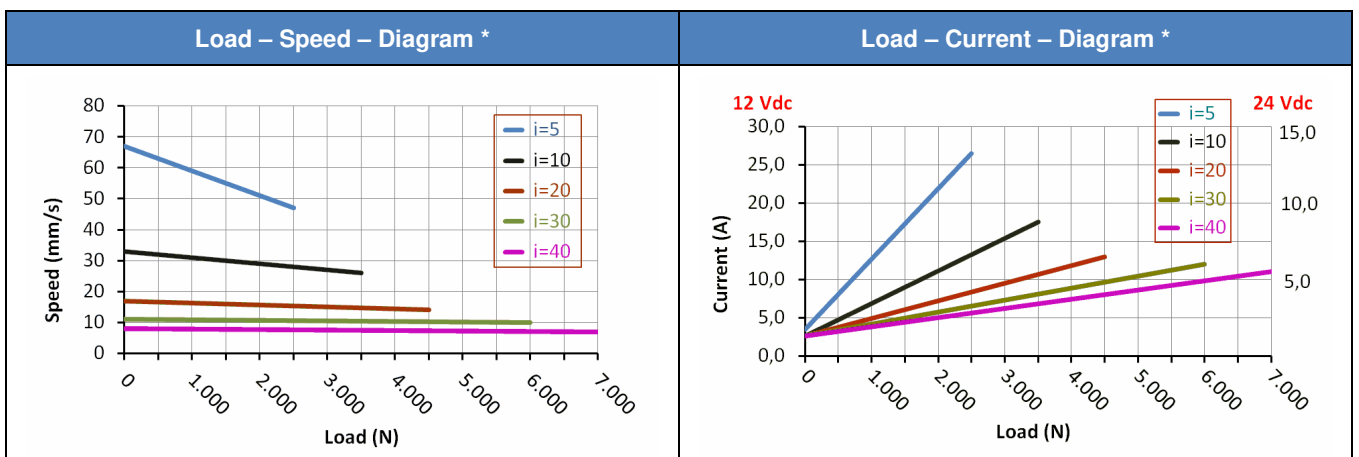

(*) Average values

Additional technical specifications

- Thrust and tensile load up to 7,000 N
- Static load up to 13,600 N (at $i=40$)
- Working temperature -25 C° to $+65\text{ C}^\circ$
- Duty cycle 25 % (2 min continuous operation – 6 min pause)
- Zinc alloy casing
- **Stainless steel** piston rod
- IP Code IP65 for all models (in idle state) - optionally: IP69K
- Mechanical overload clutch
- CE - EMV 2014/30/EU
- EN - 55014-1:2017
- EN - 55014-2:2015

Dimensions

Dimensions (length) in mm (Tolerance ± 5 mm)						
Stroke (S)	100	150	200	300	450	600
(A) retracted	319	369	419	519	719	869
(B) extended	419	519	619	819	1,169	1,469

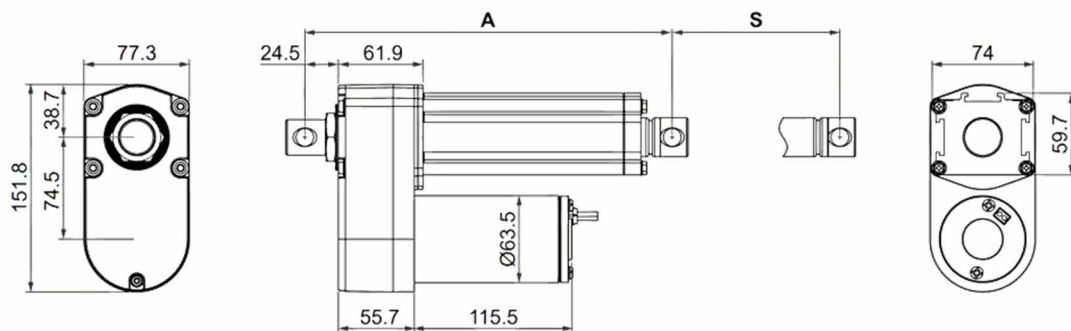

Weight

Stroke in mm	Type	100	150	200	300	450	600
Weight in kg (incl. packing) approx.	STD-ER2						

Pin assignment

Gear reduction i	5 – 10 – 20	30 – 40
Red	Red wire to Vdc „+“ and black wire to Vdc „-“:	Red wire to Vdc „-“ and black wire to Vdc „+“:
Black	Pistoon rod extends	Pistoon rod extends

External limit switches ER2 (reed sensors)

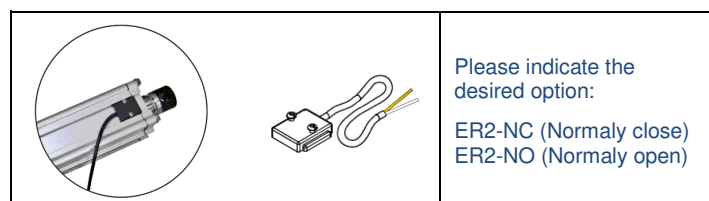

Front and rear connector

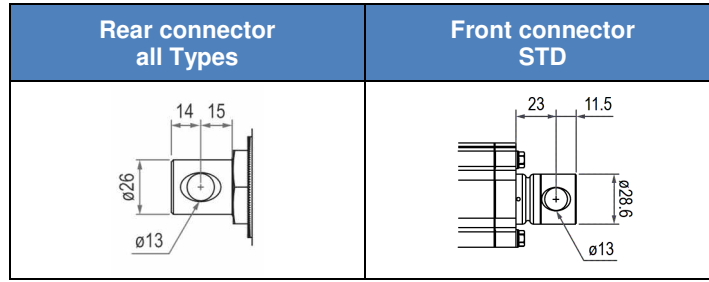

Rear connector (Fastening to the gearbox cover)	
<p>Note: As an example in 0° orientation</p>	
<p>The mounting holes on the piston rod and on the gearbox cover are designed in the 0° orientation as standard. Optionally, a different angle (see picture) can be selected for the gearbox cover and piston rod. The angle between the selectable stages is 30° in each case.</p>	
<p>Option 0 to F is appended to the type code: e. g. DSZY13...-F6 The 1st number/letter stands for the gearbox cover. The 2nd number/letter stands for the piston rod.</p>	

Mounting material

Mounting bracket DSZY2/3/5/6/8-H02	

Installation instructions

Please note the correct supply voltage as indicated on the electric linear actuator. It must be ensured that the load is not greater than shown in the diagram. To protect against overload, the voltage must be switched off when the maximum current is reached. This can be read in the diagram depending on the selected reduction ratio.

The piston rod is secured against rotation.

In an emergency, the linear actuator is protected by a mechanical overload clutch. The response of this clutch is expressed in a loud rattling tone.

CAUTION: The overload coupling is not designed for continuous use. Instead, it is intended for emergencies, for example, if current monitoring fails. The use of external limit switches is therefore strongly recommended in the standard model.

CAUTION: Please observe the correct wiring for the retraction or extension (see pin assignment in the data sheet).

The load should always be centered in the direction of movement. Transverse forces must be avoided. They always shorten the service life and can impede the function or even destroy the device in extreme cases.

 MSW Motion Control GmbH	Drive System Europe by MSW[®] A trade mark of MSW Motion Control GmbH	
	MSW Motion Control GmbH Vertriebsgesellschaft Schloßstr. 32/34, 33824 Werther (Westf.) Germany	anfrage@msw-motion.de www.msw-motion.de Phone: +49 (0)5203 919200