

Linear actuator DSZY2-POT (Potentiometer)

DSZY2 electric linear actuators are required in a wide variety of applications. Therefore, it is available in six models:

1. DSZY2-STD (Standard)
(for all applications without position feedback)
2. **DSZY2-POT**
(with potentiometer for absolute position feedback)
3. DSZY2-HS2
(with 2-channel Hall sensor for incremental position feedback)
4. DSZY2-LT
(with integrated, adjustable limit switches)
5. DSZY2-LT-POT
6. DSZY2-LT-HS2

Equipped with a trapezoidal screw spindle (ACME screw), it is a durable and robust DC linear drive, thus achieving high self-locking. In addition, mechanical overload protection has been integrated.



Type code (all options can be combined)

DSZY2 - 12 - 10 - 203 - POT - IP65					
Type	Input voltage	Gear reduction i	Stroke	Model	IP Code
	12 Vdc	10	102 mm	POT: Potentiometer	
	24 Vdc	20	153 mm	(without limit switches,	
		40	203 mm	with position feedback)	
			254 mm		
			305 mm		
			457 mm		
			610 mm		

Performance data: Load – Speed – Current

Gear reduction i	Dynamic load (N)	Static load (N)	Typical speed * (mm/s)		Typical current * (A)			
			minimum load	maximum load	minimum load		maximum load	
			12 Vdc	24 Vdc	12 Vdc	24 Vdc	12 Vdc	24 Vdc
10	1,500	approx. 3,000	33.5	26.7	2.6	1.6	17.6	8.8
20	2,500	approx. 5,000	16.8	14.3	2.6	1.6	13.2	6.6
40	3,500	7,500	8.4	7.5	2.6	1.6	11.0	5.5

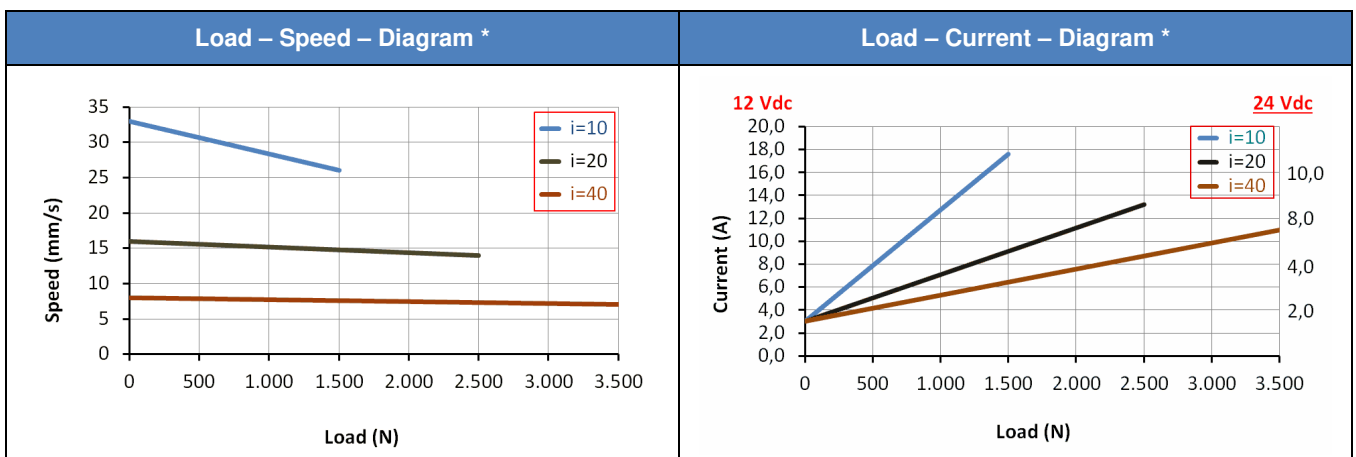

(*) Average values

Additional technical specifications

- Thrust and tensile load up to 3,500 N
- Static load up to 4,500 N (at $i=40$)
- Working temperature -25 C° to +65 C°
- Duty cycle 25 % (e.g. 2 min continuous operation – 6 min pause)
- Zinc alloy casing
- Steel outer tube
- IP Code IP65 for all models (in idle state)
- CE - EMV 2014/30/EU (EN 61000-6-3:2007+A1:2011)
- EN -61000-6-1:2007
- IEC 61000-4-2:2008
- IEC 61000-4-3:2006+A1:2007+A2:2100
- IEC 61000-4-8:2009

Dimensions

Dimensions (length) in mm (Tolerance ± 5 mm)							
Stroke (S) ± 3 mm	102	153	203	254	305	457	610
(A) retracted	302	353	404	454	505	708	861
(A+S) extended	404	506	607	708	810	1,165	1,471

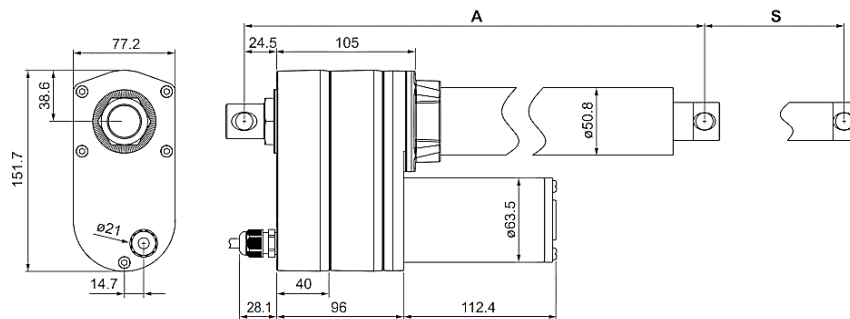

Weight

Stroke in mm	Type	102	153	203	254	305	457	610
Weight in kg (incl. packing) approx.	POT							

Pin assignment

Gear reduction i	05 – 10 – 20 – 30 – 40
Red	Red wire to Vdc „+“ and black wire to Vdc „-“:
Black	Piston rod extends

Potentiometer

Power		Potentiometer (10 kOhm)		
Red	Black	White	Yellow	Blue
		GND	Vcc	Data

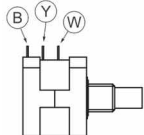

Stroke (mm)	102	153	203	254	305	457	610
Resistor value (kOhm) Tolerance: ± 0.3 k Ω	0.3 - 8.1	0.3 - 8.7	0.3 - 9.2	0.3 - 7.4	0.3 - 8.8	0.3 - 9.4	0.3 - 9.9

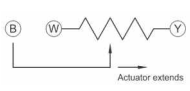

Potentiometer: 10 kOhm at 10 turns - Total resistance tolerance: ± 5 % - Vcc max. 70 Vdc

Front and rear connector

Rear connector all Types	Font connector (piston rod) POT, HS2, LT, LT-POT, LT-HS2

Fastening to the gearbox cover

Note: As an example in 0° orientation

The mounting holes on the piston rod and on the gearbox cover are designed in the 0° orientation as standard. Optionally, a different angle (see picture) can be selected for the gearbox cover and piston rod. The angle between the selectable stages is 30° in each case.

Option C1 to C5 is appended to the type code: DSZY2.....-C34
The 1st number stands for the gearbox cover. The 2nd number stands for the piston rod.

Mounting material

Clamp DSZY2/3/5/6/8-H01	Mounting bracket DSZY2/3/5/6/8-H02

Installation instructions

Please note the correct supply voltage as indicated on the electric linear actuator. It must be ensured that the load is not greater than shown in the diagram. To protect against overload, the voltage must be switched off when the maximum current is reached. This can be read in the diagram depending on the selected reduction ratio.

The piston rod is secured against rotation.

In an emergency, the linear actuator is protected by a mechanical overload clutch. The response of this clutch is expressed in a loud rattling tone.

CAUTION: The overload coupling is not designed for continuous use. Instead, it is intended for emergencies, for example, if current monitoring fails. The use of external limit switches is therefore strongly recommended in the standard model.

CAUTION: Please observe the correct wiring for the retraction or extension (see pin assignment in the data sheet).

The load should always be centered in the direction of movement. Transverse forces must be avoided. They always shorten the service life and can impede the function or even destroy the device in extreme cases.

 MSW Motion Control GmbH	Drive System Europe by MSW® A trade mark of MSW Motion Control GmbH	
	MSW Motion Control GmbH Vertriebsgesellschaft Schloßstr. 32/34, 33824 Werther (Westf.) Deutschland	anfrage@msw-motion.de www.msw-motion.de Phone: +49 (0)5203 919200